

Х.Р. САНАКУЛОВ, Д.П. ХОДИЕВА, А.Р. САНАКУЛОВА

# ТЕХНОЛОГИЯ

Жалпы орта білім беретін мектептердің  
3-сыныбына арналған оқулық

*Өзбекстан Республикасы  
Халыққа білім беру министрлігі баспаға ұсынған*



«ШАРҚ» БАСПА ПОЛИГРАФИЯЛЫҚ  
АКЦИОНЕРЛІК КОМПАНИЯСЫНЫҢ  
БАС РЕДАКЦИЯСЫ  
ТАШКЕНТ – 2019

УОК: 372.831(075)

КБК 74.263

S – 30

### П і к і р ж а з ғ а н д а р :

- М.Жумаев** – Низами атындағы ТМПУ-дің профессоры;
- Л.Бекова** – Республика Білім орталығының методисті;
- М.Мухиддинова** – Ташкент қаласы 81-мектептің технология пәні оқытушысы;
- Н.Комилова** – Ташкент қаласы 104-мектептің технология пәні оқытушысы.

### Шартты белгілер:



– тапсырма



– кәсіптер туралы мәлімет



– сұрақ



– үйде орында



– ескерту



– өзіндік жұмыс

С–30 **Санакулов Х.** және басқалар.

**Технология:** 3-сынып үшін оқулық. – Т.: «Шарқ», 2019. – 80 б.

І. 1,2. Авторлар.

УУК: 372.831(075)

КБК 74.263

**Республикалық мақсатты кітап қоры қаржысы  
есебінен басылды.**

ISBN 978-9943-26-906-4

© Х. Санакулов, Д. Ходиева, А. Санакулова.  
© «ШАРҚ» БПАК Бас редакциясы, 2016, 2019.

## КІРІСПЕ

Сен 2-сынып «Технология» сабақтарында табиғи және түрлі материалдардан құстар, хайуандар, шағын көлемдегі ойыншықтар, модельдер жасауды, жұмыс құралынан қауіпсіздік ережелерін сақтаған тәрізде пайдалануды үйрендің.

Енді 3-сыныпта табиғи және түрлі материалдардан орындалуы тұрғысынан күрделі, көп басқышты әшекейлі ойыншықтар, макет пен модельдерді жасауды үйренесің.

Практикалық жұмысты орындау үдерісіне шығармашылықпен жандасып, жаңа жобаларды даярлауда жұмыс құралдарынан дұрыс және тиімді пайдалану дағдыларын дамытасың.

Бұл оқулықтың беттерінде берілген жұмыс үлгілерін әдемі және сапалы орындауда мұғаліміңнің кеңесі, ата-анаңның көмегінен пайдалан.

Ардақты оқушылар, оқулықта берілген жұмыс үлгілерін орындаумен бірге олардың жаңа көріністерін жасап, ойлап табуға әрекет жаса.

Болашақта сені ұлы жұмыстар күтіп тұрғандығын ұмытпа.

Бұл оқулықтың саған жақын көмекші болуына сенеміз.

# ТЕХНОЛОГИЯ САБАҒЫНДА ОРЫНДАЛАТЫН ЖҰМЫС ҮЛГІЛЕРІ

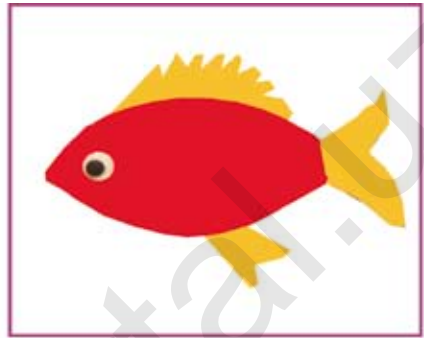
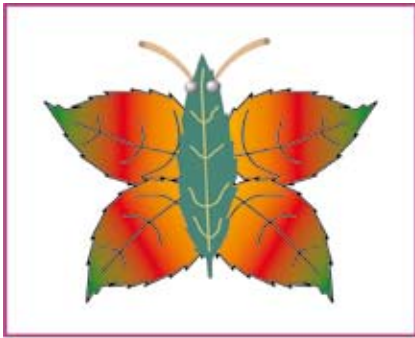

# «КҮЗДІҢ» КӨРІНІСІН АППЛИКАЦИЯ ӨДІСІНДЕ ЖАСАУ

## Бізге қажетті жұмыс құралдары

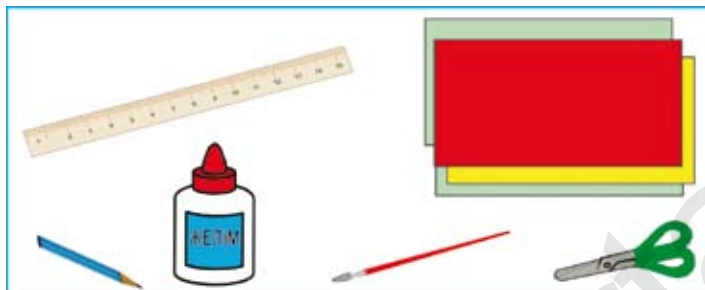

Күздің көрінісіне сай детальдарды даярлап ал.

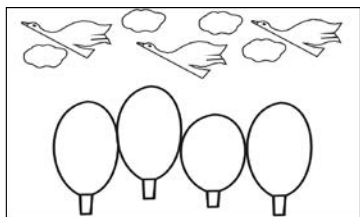

Баудағы ағаштардың орналасу тәртібін бақылап көр. Түсті қағаздардан ағаштың қалыптарын қырқып, рет-ретімен жайғастырып желімде.

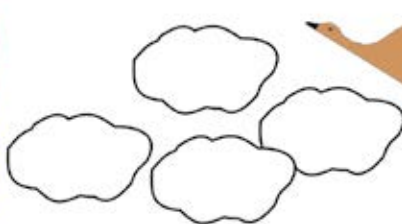

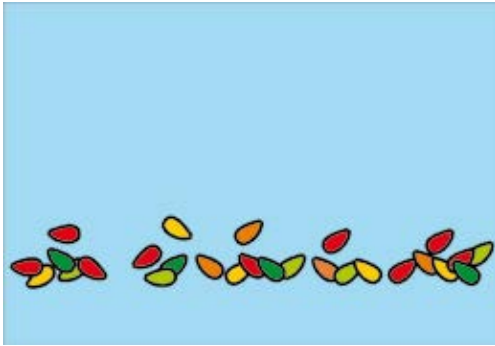

4



5

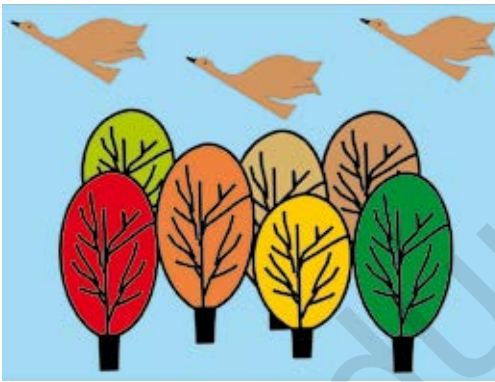

6



7



Әрбір жыл мезгілін өз көрінісінде суреттеуге әрекет жаса.



## КӨБЕЛЕКТИҢ ПІШІНІН ҚҰРАСТЫРУ, ЖАСАУ

! Көбелектің пішініне сай жапырақтарды топтастыр және тазалап кептір.

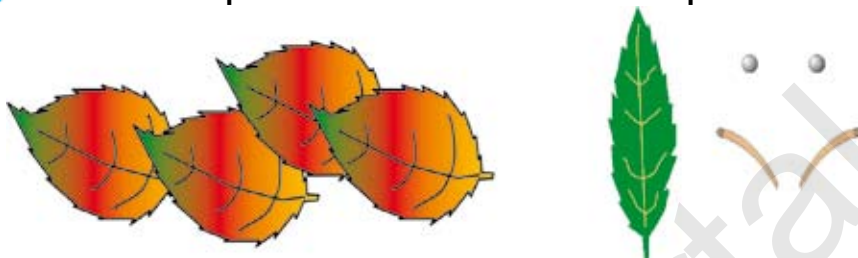

! Көбелектің пішінін жасаудан алдын көбелектің сызбасын сызып ал.

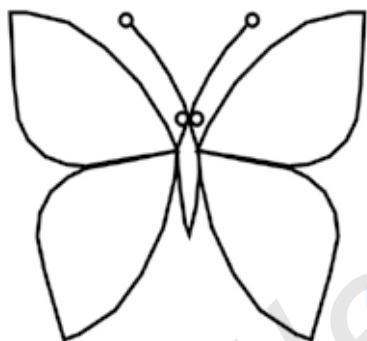

1



2

! Құрғатылған жапырақтарды бір-біріне сай етіп дұрыс орналастыр және желімдеп қой.

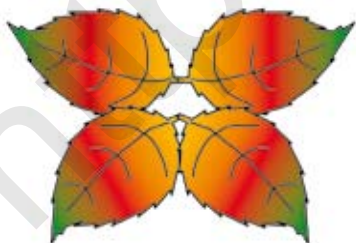

3



4



Өзіндік жұмыс үлгілері.



1



2



Көбелектің пішінін қандай материалдардан жасауға болады?

Сен қандай көріністегі көбелекті өздігіңнен жасай аласың?



3



4





Өзіндік жұмыс үлгілері.



## ҚОЗҒАЛАТЫН ОЙЫНШЫҚТАР ЖАСАУ



Картонға қонжықтың бөліктерін сыз және қырқып ал.

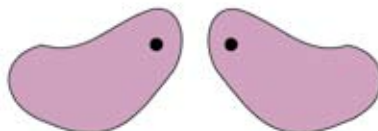
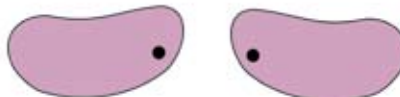
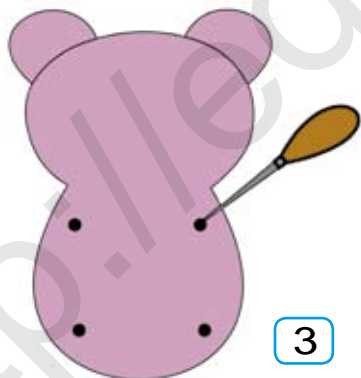
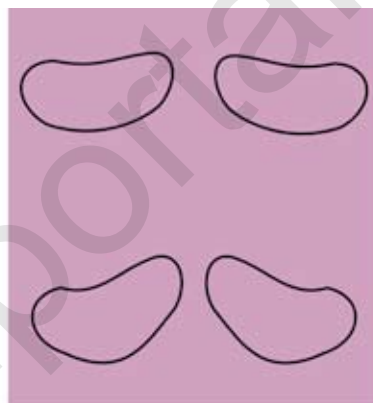
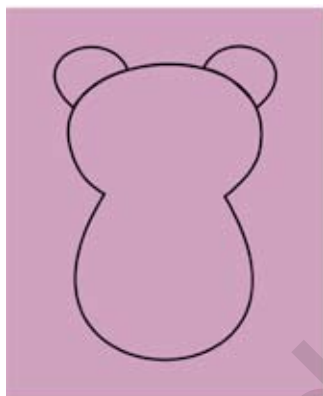

Қонжықтың бөліктерін біріктіру нүктелерін белгіле, мұғалімнің бақылауында тесіп ал.



Қонжықтың бөліктерін төмендегі тәртіпте біріктіріңіз.

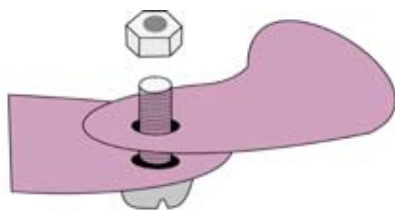

5

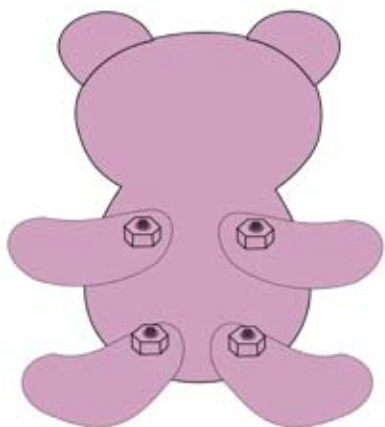

6

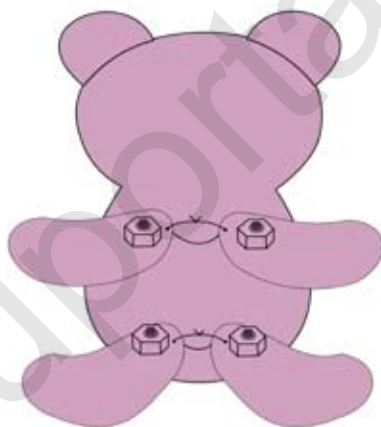

7

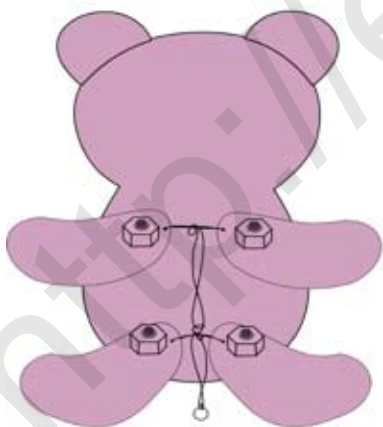

8



9



Өзіндік жұмыс үлгілері.



Қозғалатын модельдерді өздігіңнен жасауға әрекет жаса.



1

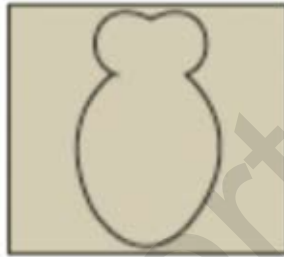

2



3

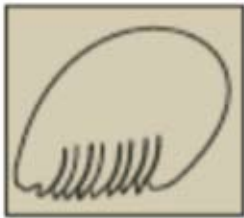

4



5



6



7

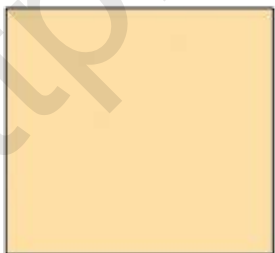

8

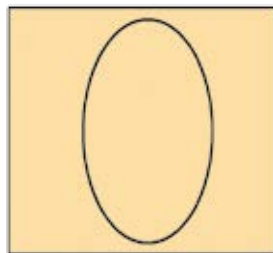

9



10

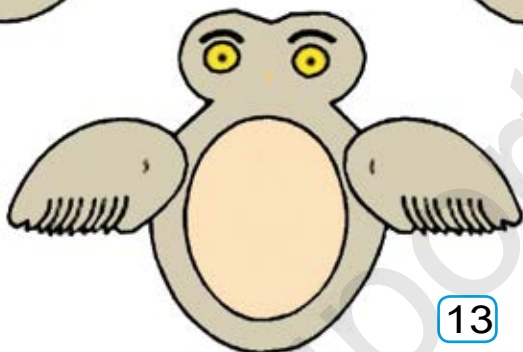
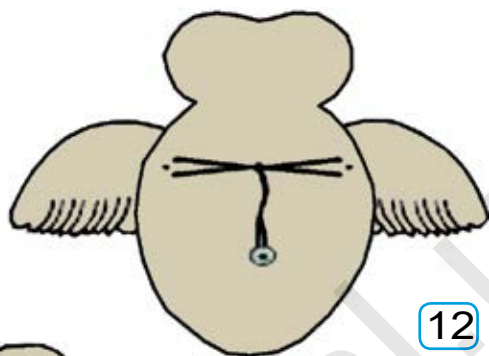
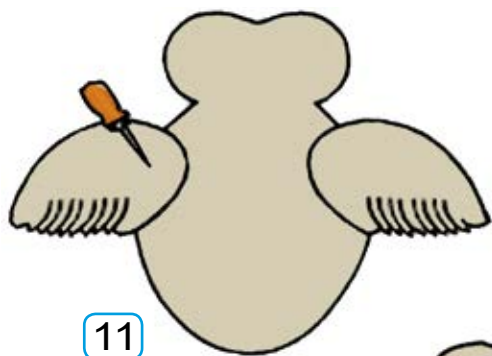

Құстың суретін аппликация әдісінде  
өздігіңнен жасап көр.



## САБАННАН АППЛИКАЦИЯ ӘДІСІНДЕ ХАЙУАНДАР, ГҮЛДЕР, ЖАНУАРЛАРДЫҢ ПІШІНІН ЖАСАУ



Үтікпен істегенде үлкендердің көмегінен пайдалан.

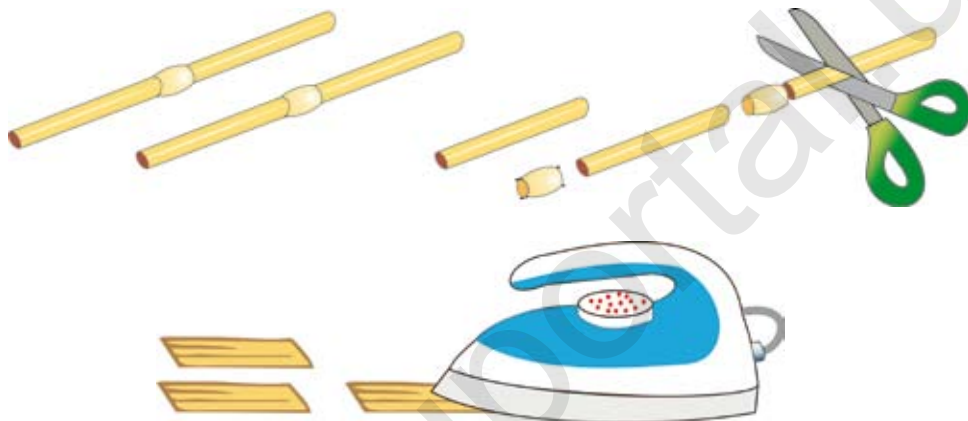

Оқытушың дайындап берген сабандарды қағазға желімде және бірізділікте орында.



1



2



3



Өзіндік жұмыс үлгілері.



Жұмыстың әрекеттерін бақыла және жасап көр.



Сабаннан әр түрлі композиция жаса және туыстарыңа сыйға тарт.

## 1-бақылау жұмысы

Жапырақтардан хайуандардың пішінін жасау





# «ЕРТЕГІ ҚАҢАРМАНДАРЫН» АППЛИКАЦИЯ ӘДІСІНДЕ ЖАСАУ

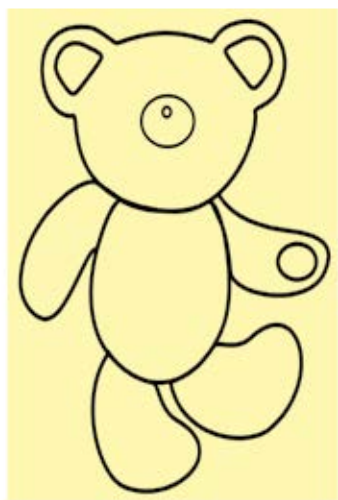

1



2



3



4

5



8



6



7

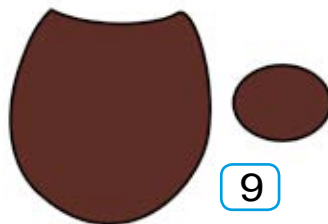

9



Әрбір басқышты рет-ретімен, дұрыс орында.



10

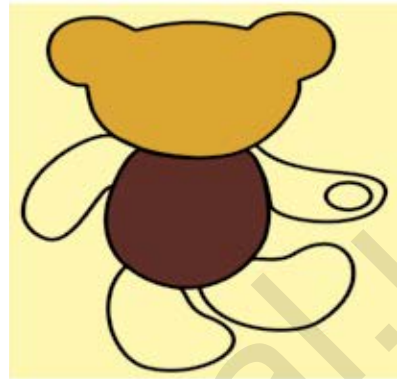

11

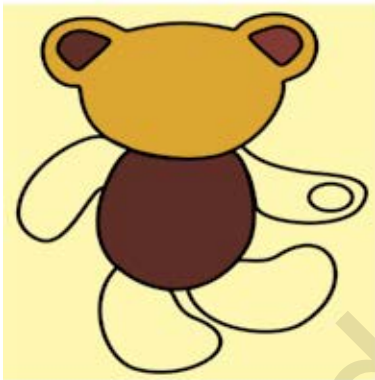

12



13



14



15



Өзің сүйген ертегі қаһармандарын  
аппликация әдісінде даярлауға әрекет  
жаса.



Өзіндік жұмыс үлгілері.

Қағаздан кірпінің пішінін өздігіңнен жасап көр.

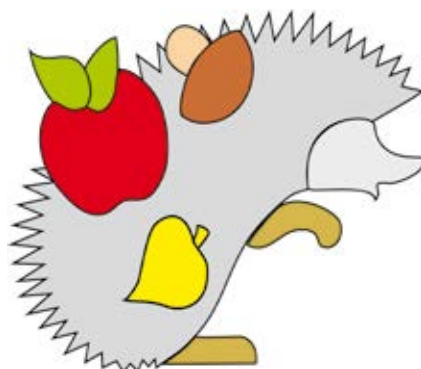
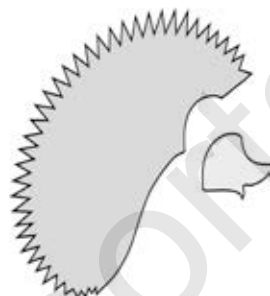

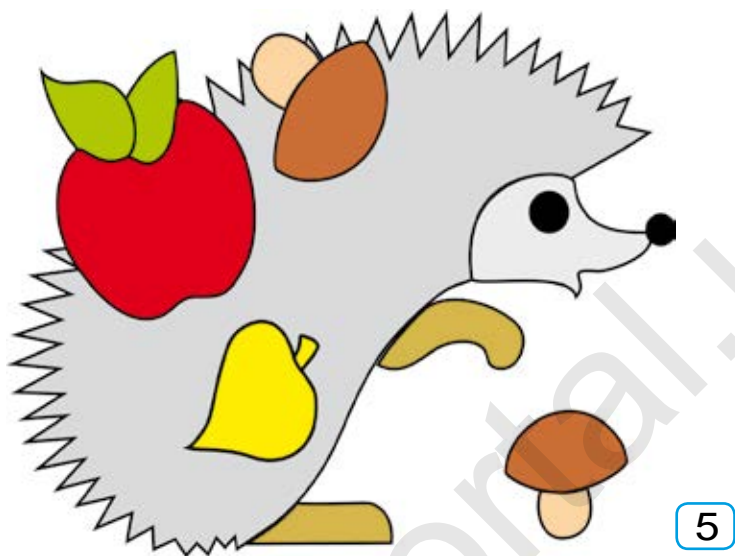

❓ Құстың пішіні қандай геометриялық пішіндерден құралған?



## ПАПЬЕ-МАШЕ ӨДІСІНДЕ ПИЯЛА ЖАСАУ ЖӘНЕ БЕЗЕНДІРУ



Пияланың сыртына вазелин немесе май жақ. Қағазды майда бөліктерге бөл. Пияланың бірінші қабатына қағаз бөліктерін суға батырып, пияланың бетіне тегіс етіп жабыстыр. Екінші қабатына қағаздың бөліктерін желімнің көмегінде жабыстырып шық.



Пияланы даярлау үшін қажетті жұмыс құралдарынан дұрыс пайдалан.



4



5



6



7



Қағаздың бөліктерін екінші қабатқа бойлай желімде. Бұл қағаз қабаттарын адасып кетуден сақтайды. Бұл жайтты 6-7 рет қайтала.



8



9

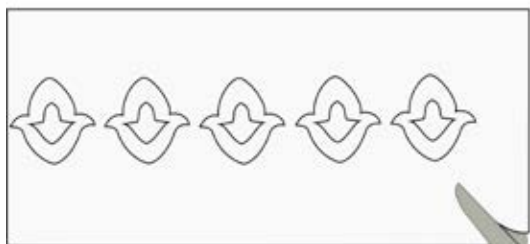

10



11



12



13



Пияланы 3 күннің ішінде құрғатуға қой.  
Соң пияланың сыртын көк түске боя  
және нақыш элементтерімен әшекейле.

## СЫЙЛЫҚ ҮШІН СУВЕНИР ЖАСАУ



1



2



Жұмсақ сымға гүлдің пішінін көрсететін гүл жапырақтары үшін екі түсті бисерлерді рет-ретімен орналастыр.



3



4



Даярланған гүлге тағы қандай қосымша енгізуге болады. Бұл жұмысқа шығармашылықпен жандас.





Бірнеше гүлдің жапырақтарын бір-біріне біріктіріп, гүлдің пішінін жаса.



5



6



Өзіндік жұмыс үлгілері.





Өзіндік жұмыс үлгілері.



Жұмыс үлгілерін бақыла. Өздігінен жасау үдерісіне өзгеріс енгізуге әрекет жаса.



## ТҮРЛІ ҚАҒАЗДАРДАН ГҮЛТІЗ- БЕКТЕРІ МЕН ҚАРДЫҢ ЖҰЛЫМЫН ЖАСАУ

! Қар жұлымын төмендегі тәртіпте жасап көр.



1



2

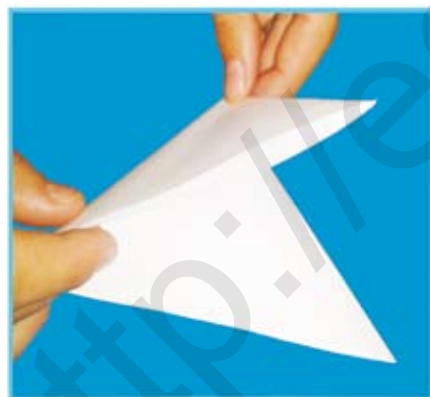

3



4

? Тағы қандай қар жұлымдарын жасауға болатынын ойлап көр?

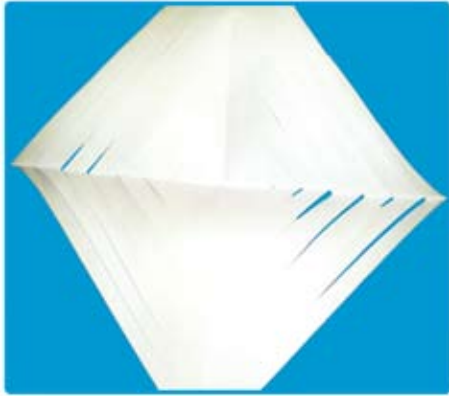

5

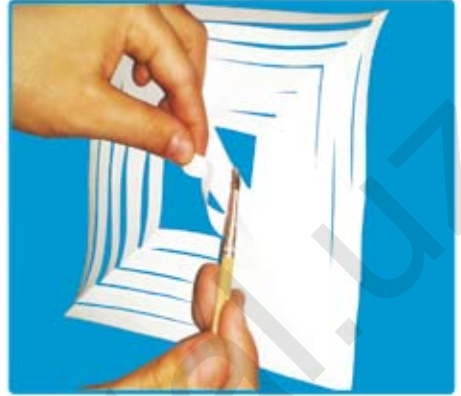

6

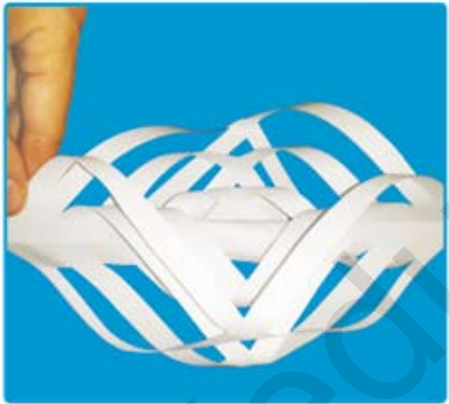

7



8



9



10



Өзіндік жұмыс үлгілері.



1



2



3



4

## ТҮСТІ ҚАҒАЗДАН ШЫРША ЖАСАУ



1



2



3



4



Қауіпсіздік ережелерін сақта.



5



6

! Қағаздың бөліктерін тәртіппен желімде.



7



8



9



10



11



12



13



Шыршаға сай ойыншықтарды жаса.



## 2-бақылау жұмысы

Түсті қағаздардан үлкен шырша ойыншығын даярла

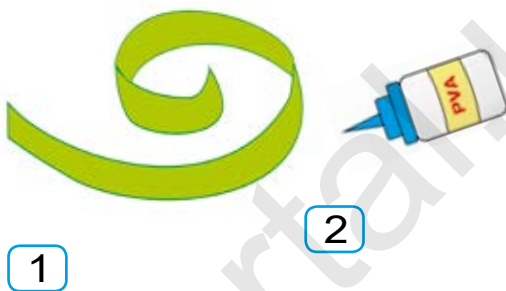
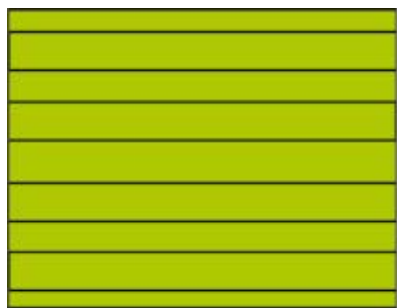

3



4



5



6

## ҚЫСТЫҢ КӨРІНІСІН АППЛИКАЦИЯ ӘДІСІНДЕ ЖАСАУ

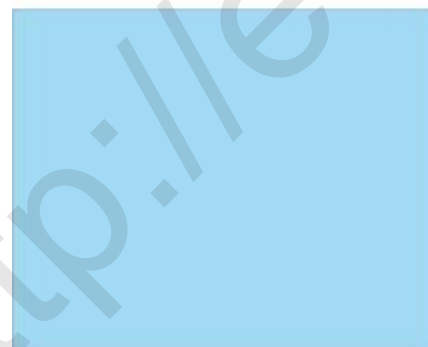
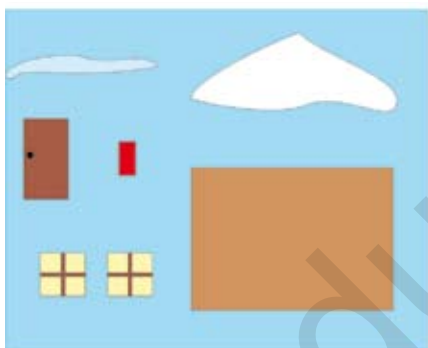
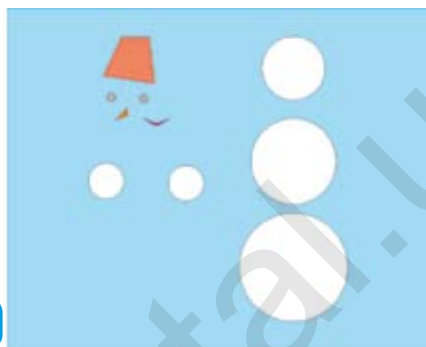
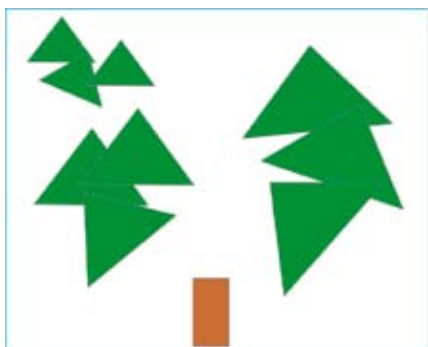

Әрбір пішінді дұрыс жайғастырып, қыстың көрінісін жаса.



7



8



Қыстың көрінісінен үлгілер жасап көр.  
«Өзбекстанда қыс» тақырыбын өздігің-  
нен аппликация әдісінде жасауға әрекет жаса.



## КЕСТЕНІ ДҰРЫС ТІГУ



Кестені дұрыс тігу үшін төмендегі ережелерді сақта.

Инемен істеу ережелері:

1. Инені істетіп болғаннан кейін арнайы ине жастықшаға қадап қойылады.
2. Инені ешқашан аузыңа салма.
3. Жұмысты тігуден алдын және кейін инелердің санын тексер, жетпеген инелерді әлбетте тауып, оны арнайы ыдысқа салып қой.

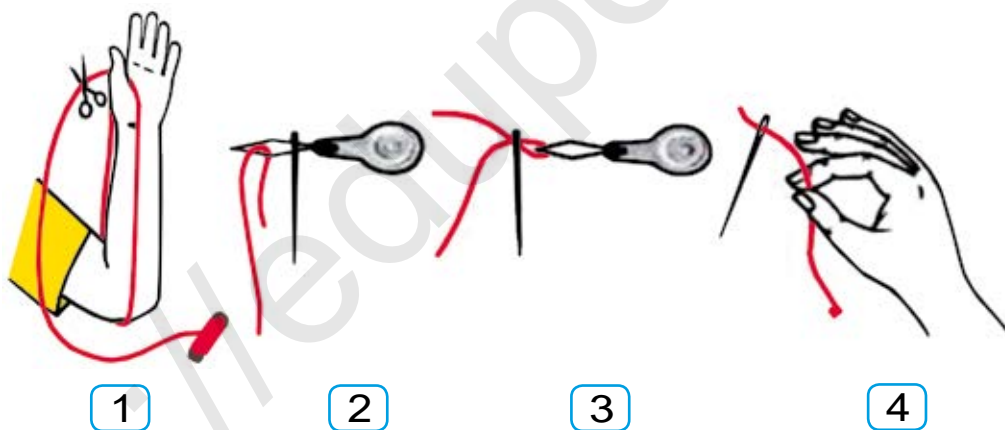

4. Қажетті ұзындықтағы жіпті өлшеп, оны қырқып ал (1-сурет).
5. Инеге жіп өткізіп, түйін жасауды ұмытпа (2,3,4-суреттер).

Кесте түрлерімен таныс.

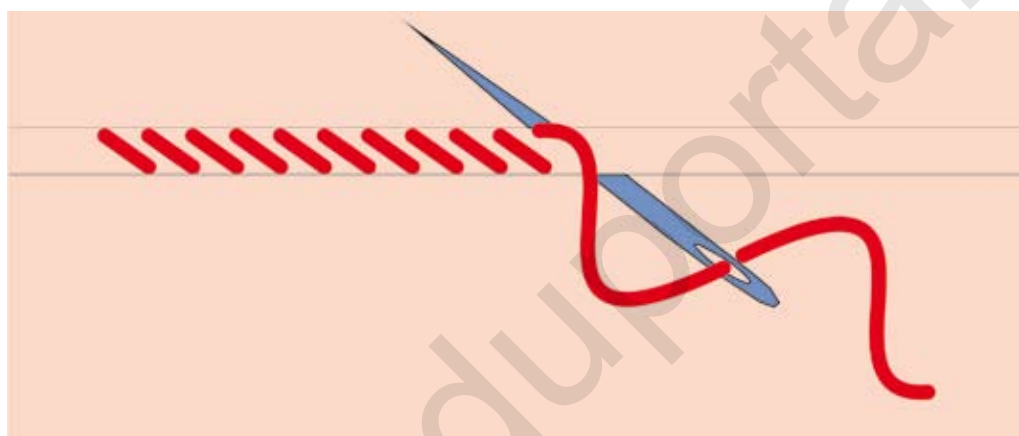
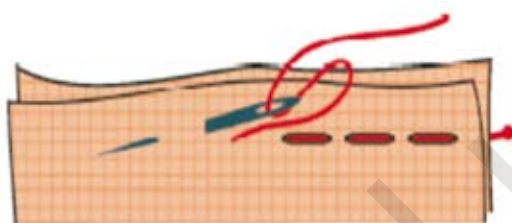
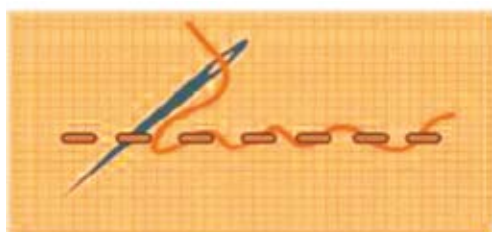

Түрлі кестелерде тігуді үйрен.

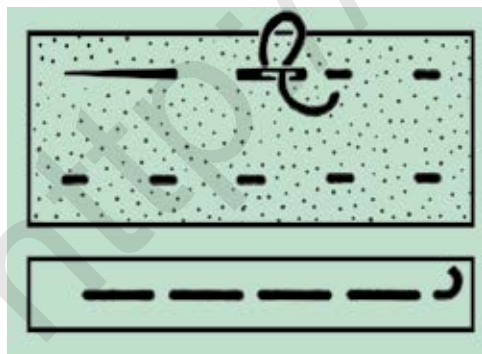



Өзіндік жұмыс үлгілері.



1



2



Картоннан даярланған үлгі негізінде мата бөліктерінен қалаған өлшемдегі (шеңбер) пішінді қырқып ал.



3



4



Қималарға дұрыс кестемен өңдеу жаса.



5



6



7



Әшекей кестелерінен пайдалан.



Өзіндік жұмыс үлгілері.

Тура кестенің көмегінде шәйнек ұстағышты тік.

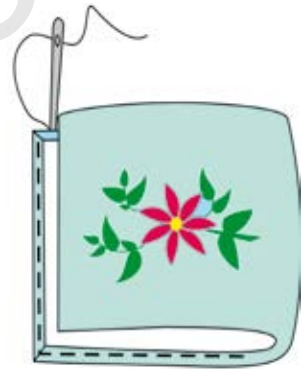
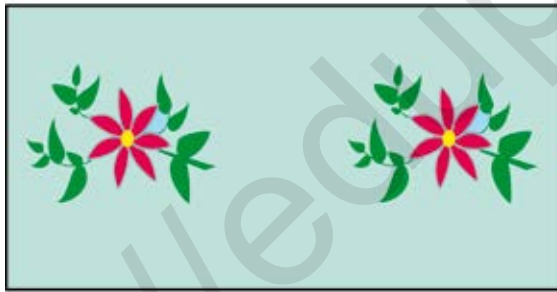
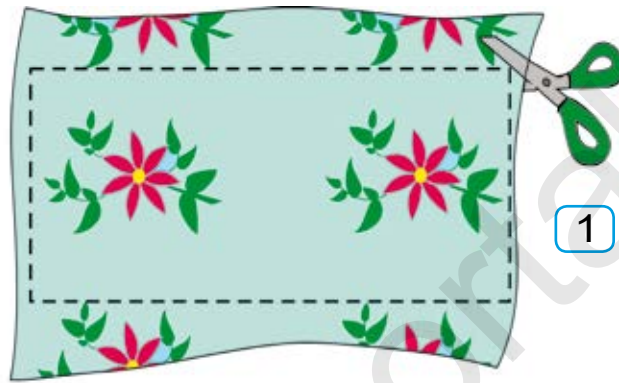



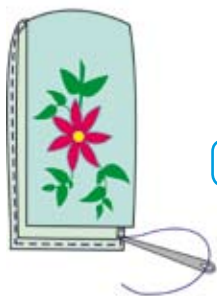

6

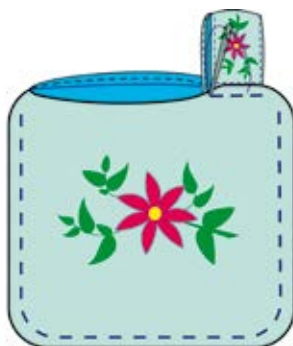

7



8

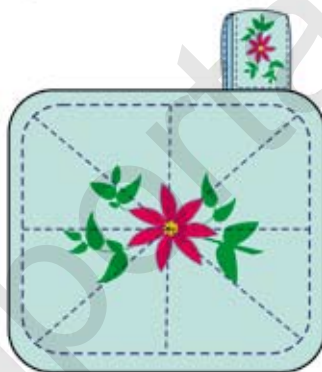

9

? Қандай ұстағыштан пайдалану қолайлы?



10



Шәйнек ұстағыштың пішініне өзгеріс енгізуге болады. Оларды даярлап көр.

## ИНЕ ҮШІН ЖАСТЫҚ ТІГУ

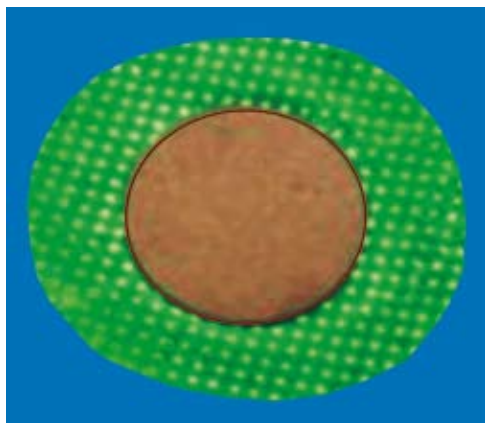

1



2



Ине үшін жастық тігу тәртібімен та-  
ныс. Практикалық жұмысқа шығарма-  
шылықпен жандасып, өз (ине үшін  
жастық) өніміңді даярла.



3



4



5



6



Инемен істегенде қауіпсіздік ережесін сақтауды ұмытпа.



7

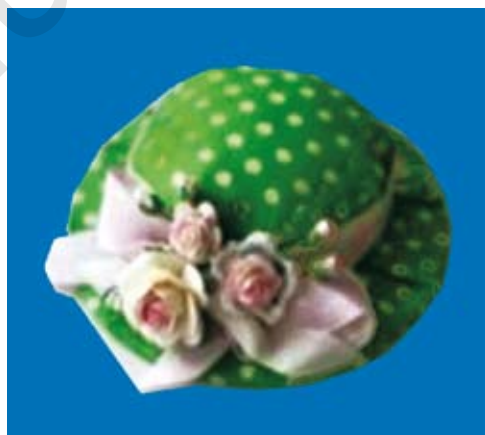

8

## ӘР ТҮРЛІ ГЕОМЕТРИЯЛЫҚ ПІШІНДЕРДЕН ҚОЗҒАЛАТЫН МОДЕЛЬДЕРДІ ҚҰРАСТЫРУ, ЖАСАУ



Шағын өлшемдегі бос кіші қораптардан қозғалатын машина моделін жасап көр.

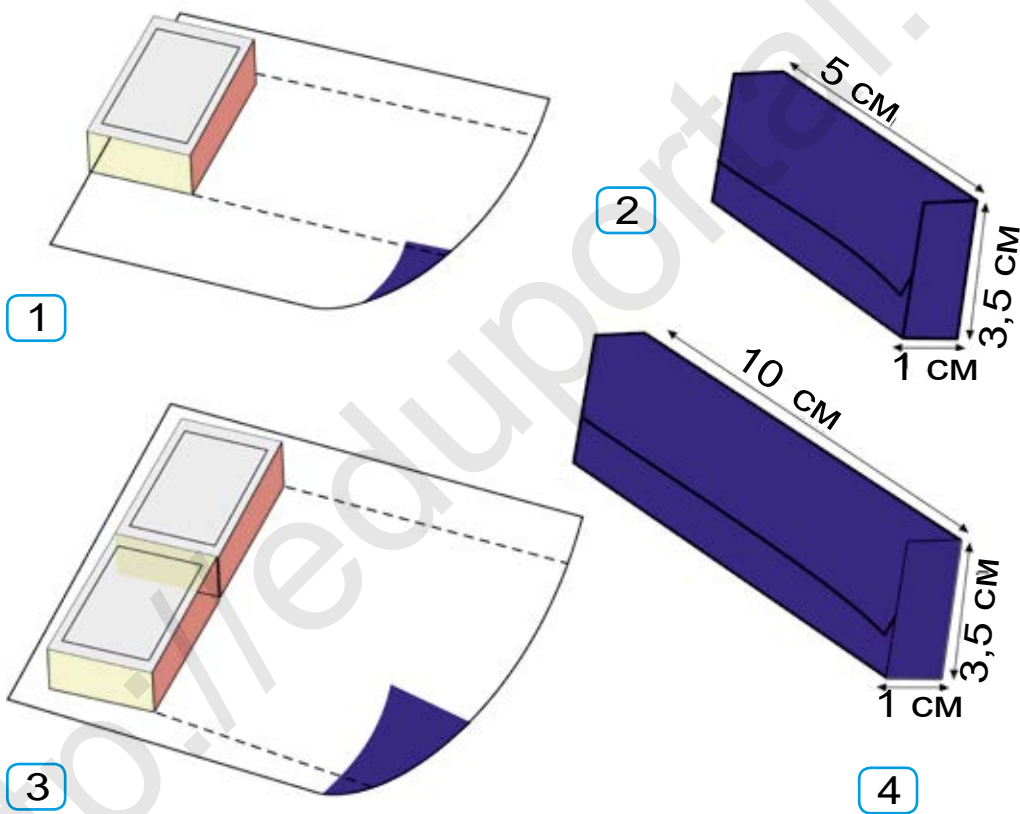

Қозғалатын машинаның модель бөліктерін дұрыс белгілеп ал.



Машинаның дөңгелектерін жасауда  
пластмасса қақпақтан пайдалан.

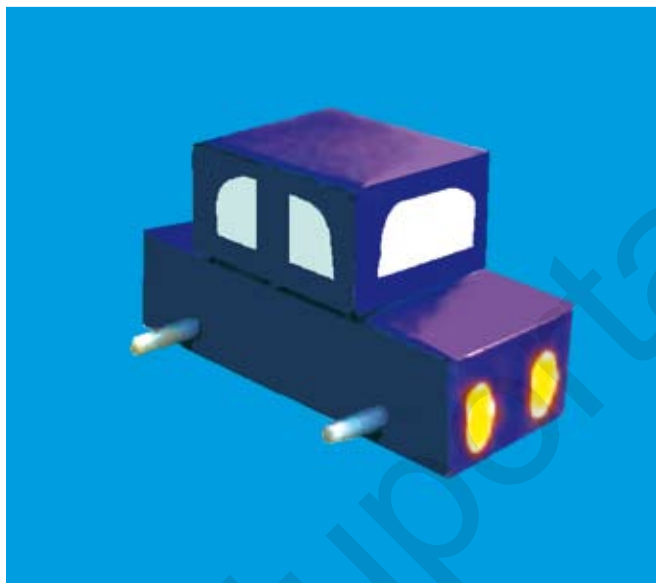

5



6



7



Көлік жүргізуші таңертеңнен күн батқанға дейін адамдарды көздеген жерлеріне қатерсіз жетіп алулары үшін қызмет етеді.

Көлік жүргізушілік кәсібі әрдайым зеректікті, сергектікті талап етеді.

## КӨКТЕМГІ ГҮЛДЕРДІҢ КОМПОЗИЦИЯСЫН ДАЯРЛАУ



1

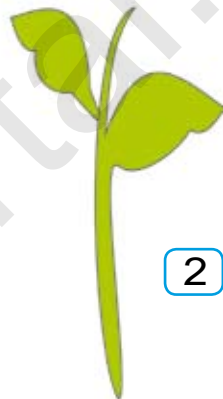

2



Көктем гүлдерін түсті қағаздардан жа-  
сап көр!

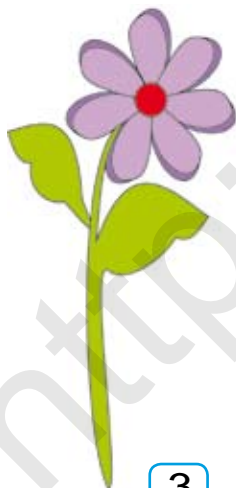

3



4



5

## ҚАҒАЗДЫ БҮКТЕУ ЖӘНЕ ҚЫРҚУ ӘДІСІНДЕ ГҮЛДЕРДІҢ ПІШІНІН ЖАСАУ



Түрлі қағаздардан көктемгі гүлдердің композициясын даярлау басқыштарын рет-ретімен орында.







# Өзіндік жұмыс үлгілері.

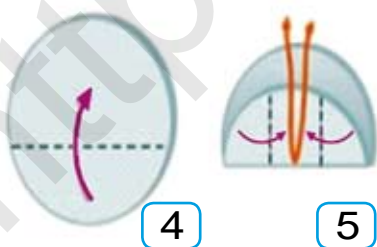
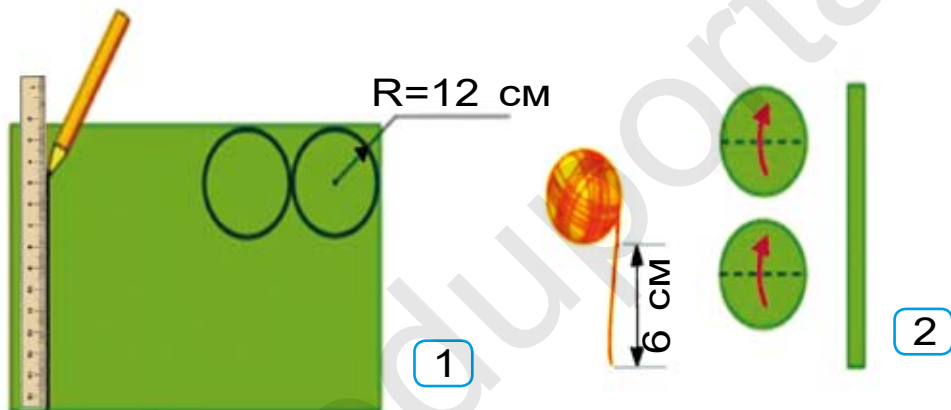

## МЕРЕКЕГЕ ҚҰТТЫҚТАУ ҚАҒАЗЫН ЖАСАУ



Қажетті жұмыс құралдарын дайындап ал.

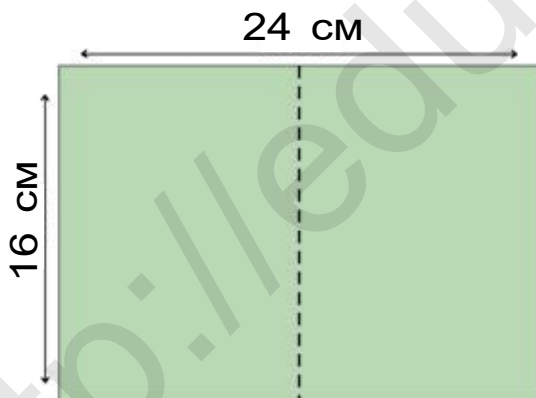
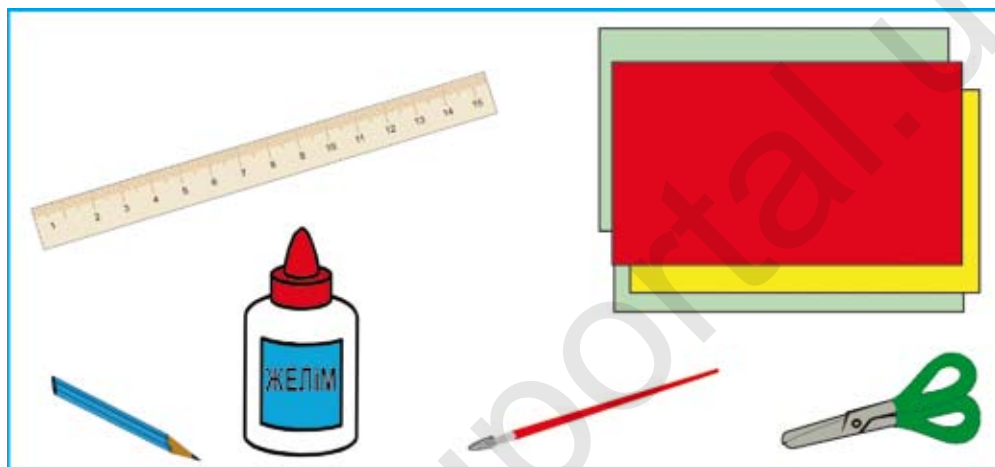

1

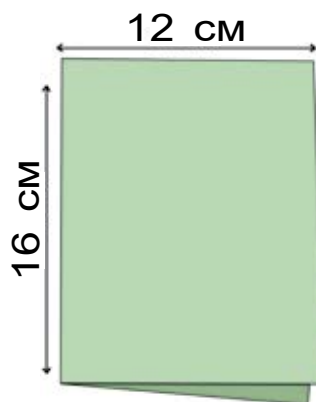

2



Құттықтау қағазын жасау үшін өлшемдерді дұрыс белгілеп ал.



Өлшемі мен түсін дұрыс таңда.

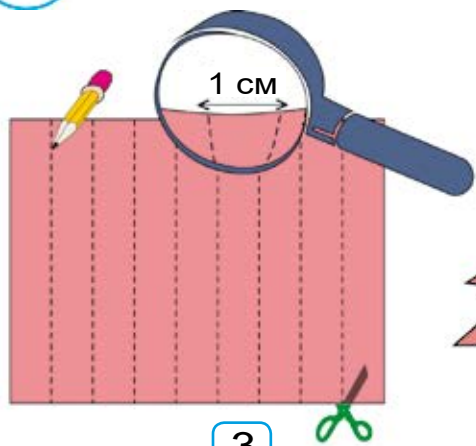

3



4

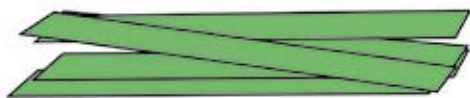

5



6

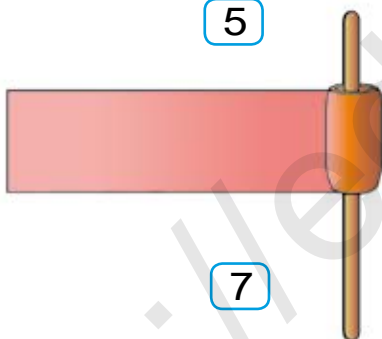

7

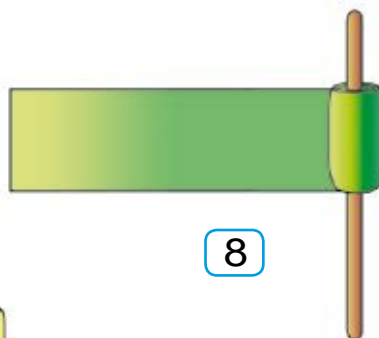

8

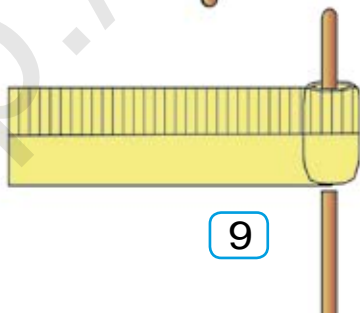

9



10



11



12



13



14



15



Квиллинг әдісінде гүлдерді даярлауда арнайы қырқылған қағаздан пайдалан.



16



17



18



19



20

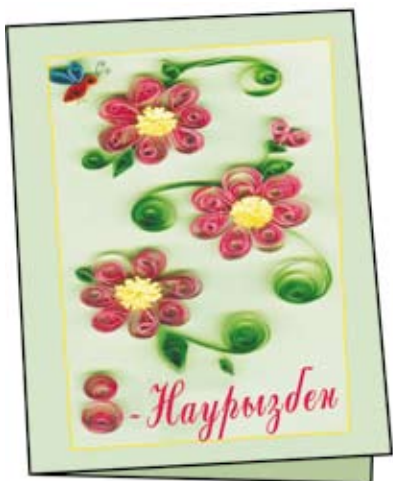

Анашым, құтты болсын,  
Әсем көктем мерекеңіз.  
Құшағыңыз гүлге толсын,  
Шаттықтарға әр деміңіз.

*Аллаберген Полат*



### 3-бақылау жұмысы

Апликация әдісінде гүлшоқ  
композициясын жаса



1



2



3



4



Өздігіңнен жасап көр.

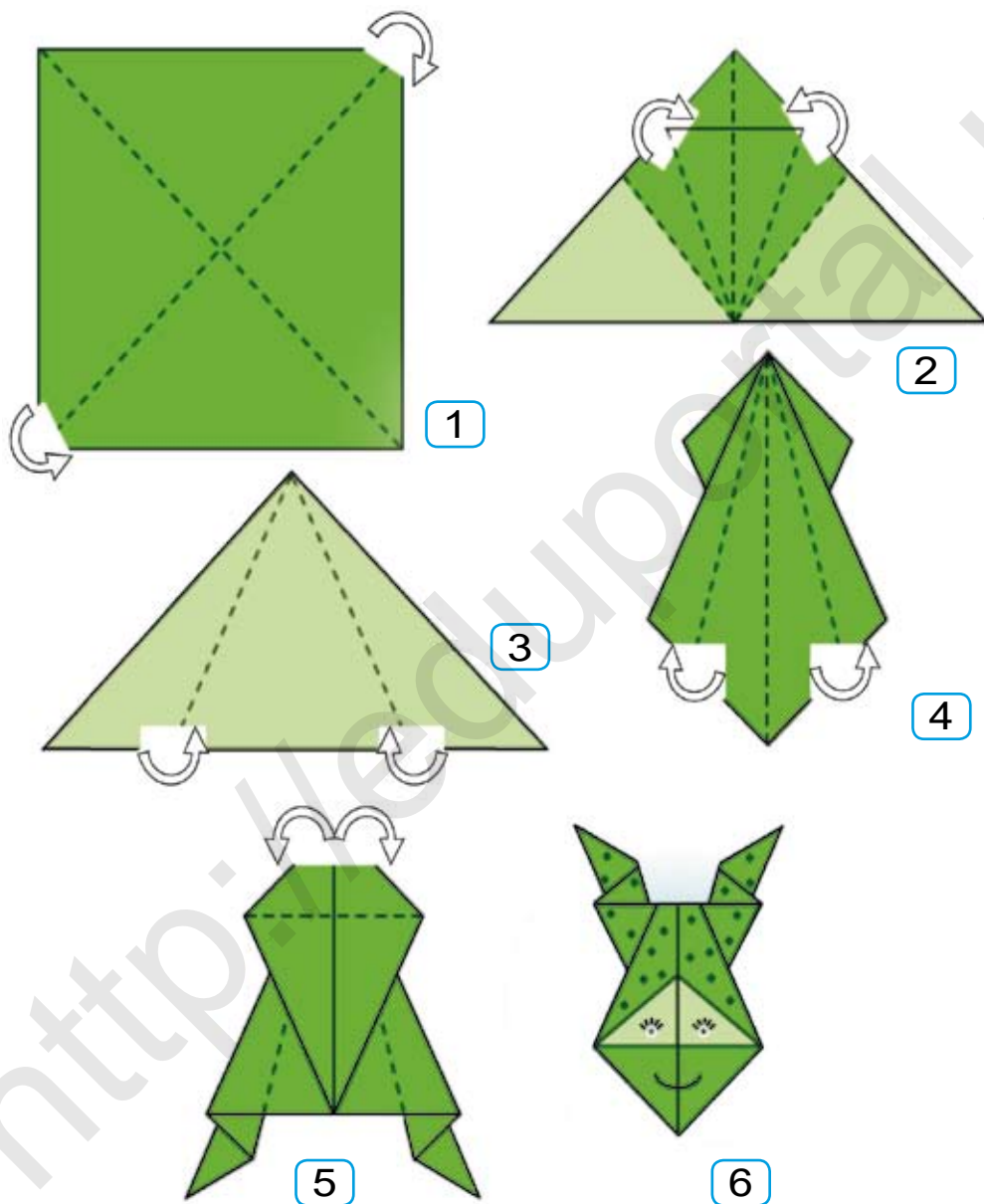

# НАУРЫЗ МЕРЕКЕСІ ҮШІН ӘШЕКЕЙЛЕР ДАЯРЛАУ

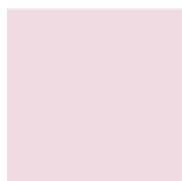

1



2



3



4



5



6





Өзіндік жұмыс үлгілері.



1



2

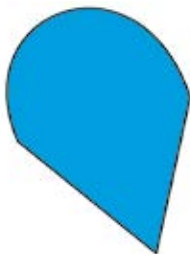

3



4



Түрлі қағаздардан мереке үшін қандай әшекейлер даярлауға болады?

# «ВАЗАДА ГҮЛДЕР» КОМПОЗИЦИЯСЫН ЖАСАУ

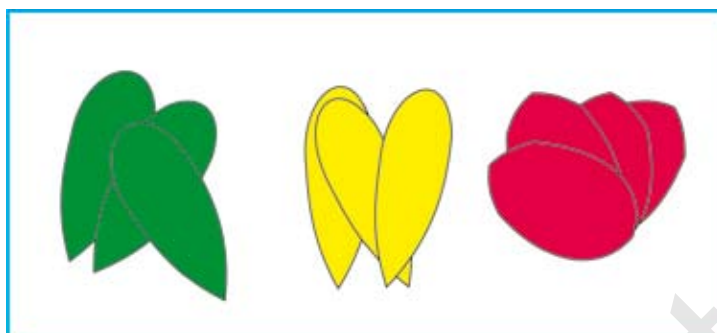

1

2



3

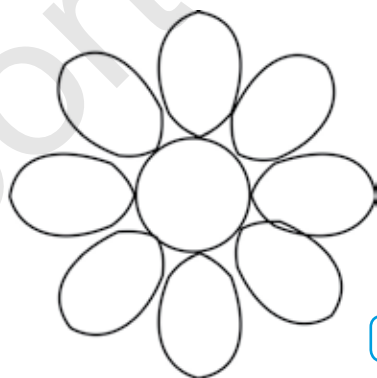

4



Дәндерді тәртіппен орналастыр.



5



6





Түрлі материалдардан гүлдердің пішінін жасап, өзіңді қаншалықты жасампаз екеніңді сынап көр!





Өздігінен орындалатын жұмыстар.

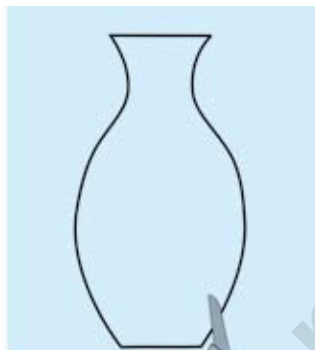
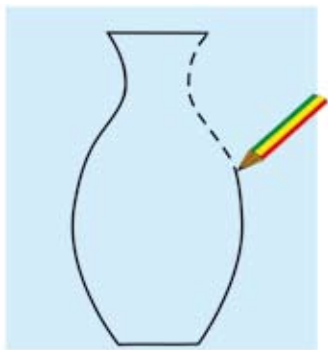

1



2



Ваза үшін үлгі дайында және оны гүлді яки түсті картонға жайғастырып қырқып ал.



3



Вазаның бөліктерін біріктіріп тігуде кесте түрлерінен пайдалан.



4



5



6

## ЖҮЗЕТІН МОДЕЛЬДЕРДІҢ МАКЕТІН ҚҰРАСТЫРУ, ЖАСАУ

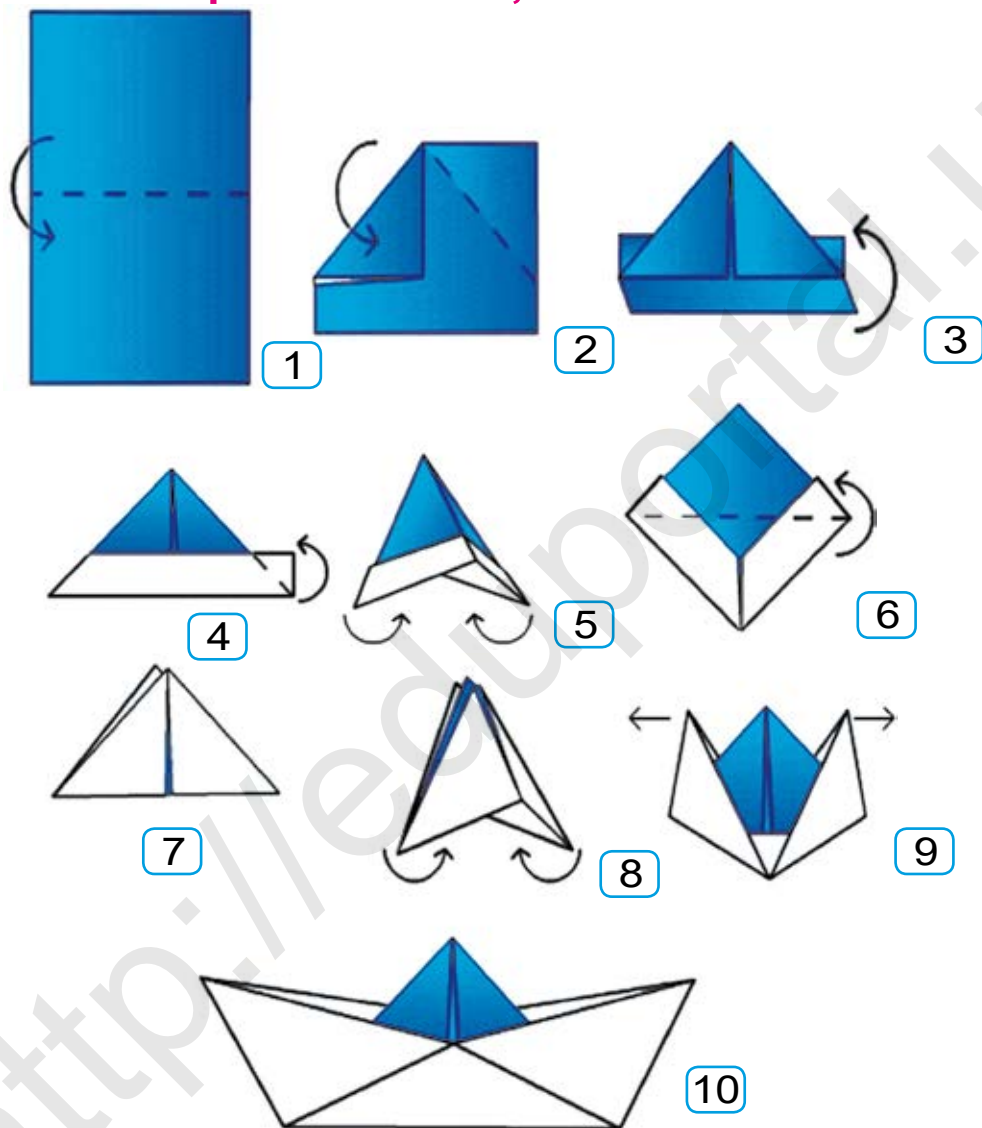

Жүзетін модельдерді жасауда қосымша деректерден пайдалан.

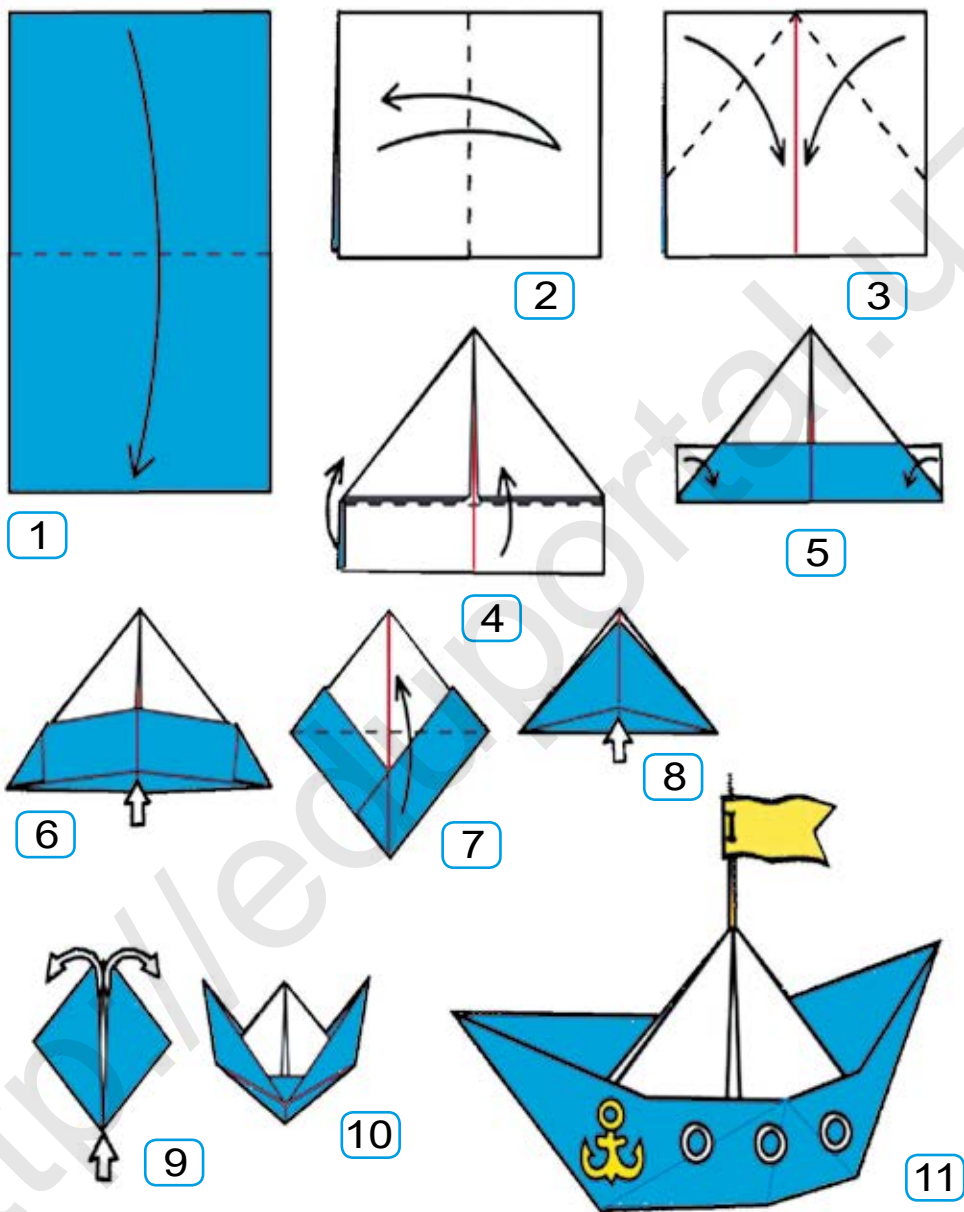

Дайын қайықты әлбетте суда жүзуін бақылап көр.



## ПОРОЛОН ЖӘНЕ ЖІПТЕН ЖҰМСАҚ ОЙЫНШЫҚТАР ДАЯРЛАУ



Поролон бөлігінен тік төртбұрыш пішінін даярла. Оған балық пішінінің бөліктерін сыз және қырқып ал.

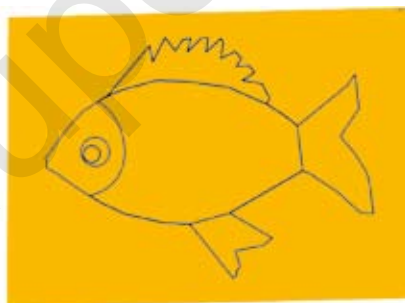

1

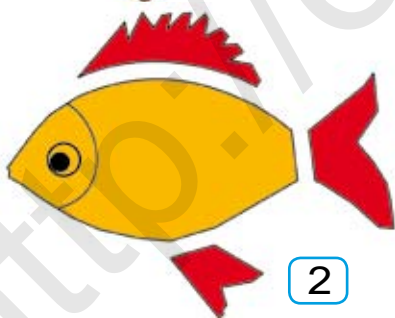

2

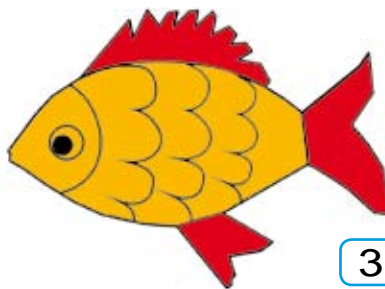

3



Балықтың бөліктерін рет-ретімен орналастырып шық.



Өздігінен орындалатын жұмыстар.

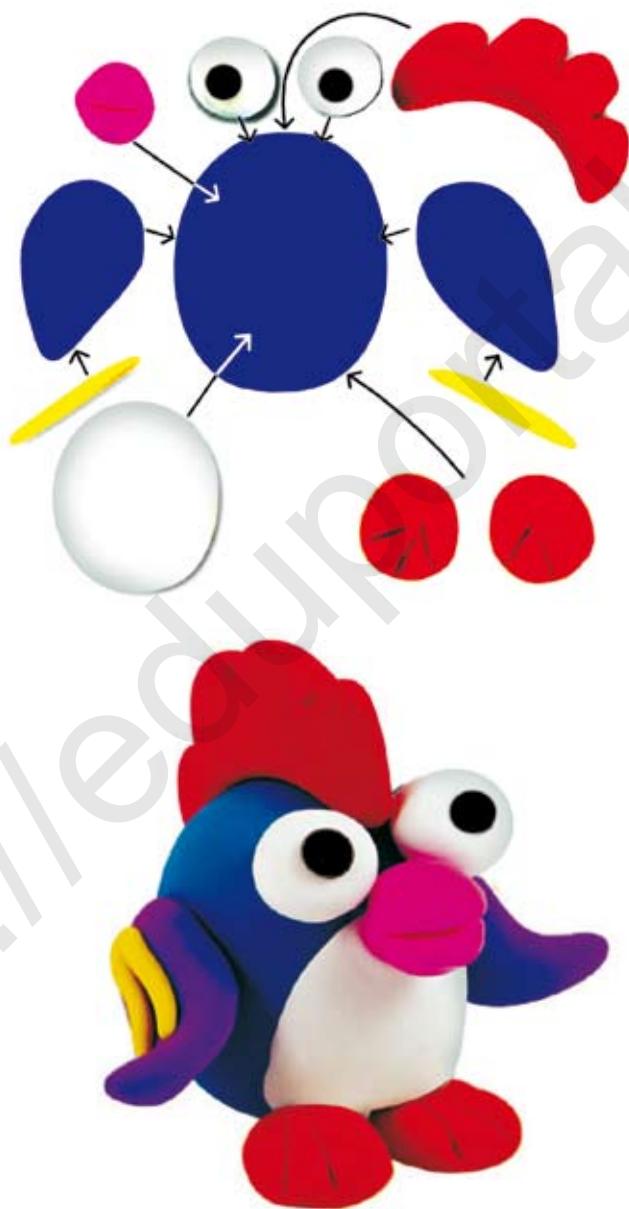

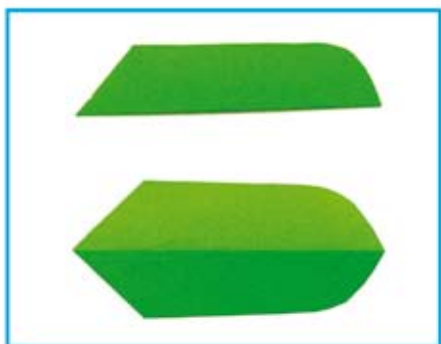

1



2



3



4



Өздігіңнен басқа хайуандарды да жа-  
сап көр.



5

## ЖІПТЕН ОЙЫНШЫҚТАР ЖАСАУ



! Жіптен түрлі ойыншықтарды жасап көр.



## ҚАҒАЗДЫ ҚЫРҚУ ЖӘНЕ БҮКТЕУ ӘДІСІНДЕ ГҮЛДЕРДІҢ ПІШІНІН ЖАСАУ



Үлкен гүлдің пішінін жасауды кезең-кезеңмен орында.

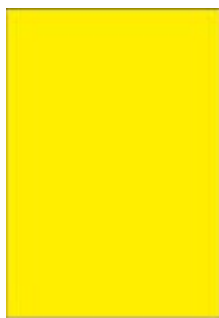

1

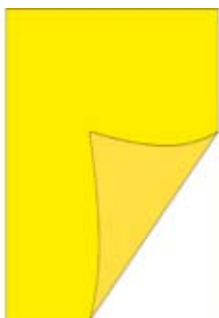

2



3

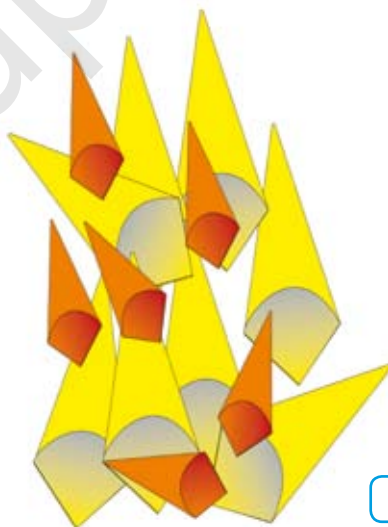

4



Қайшыдан дұрыс пайдалану ережелерін сақта.



Жұмысты рет-ретімен орында.

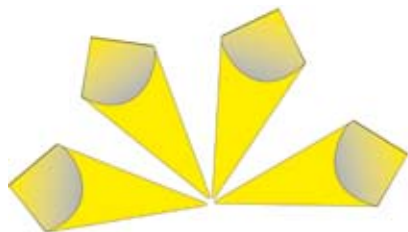

5

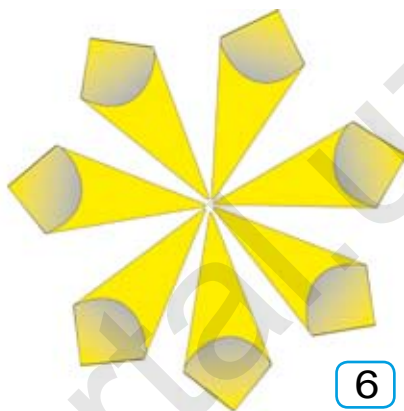

6

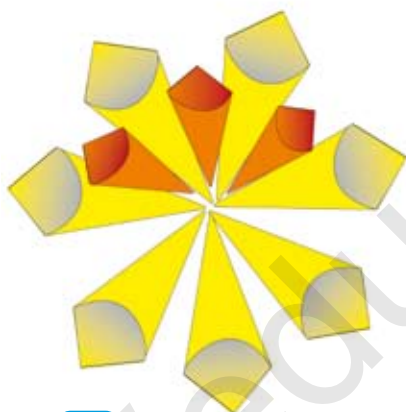

7

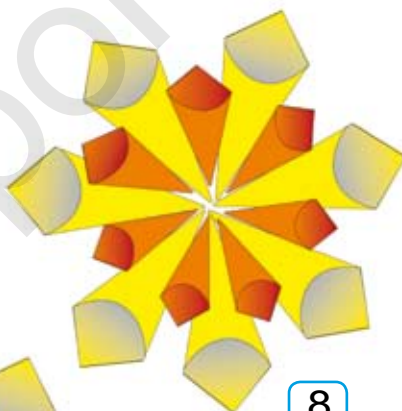

8

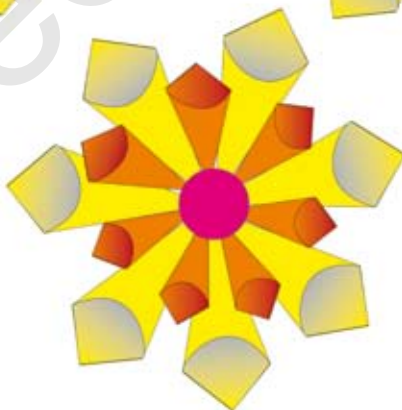

9

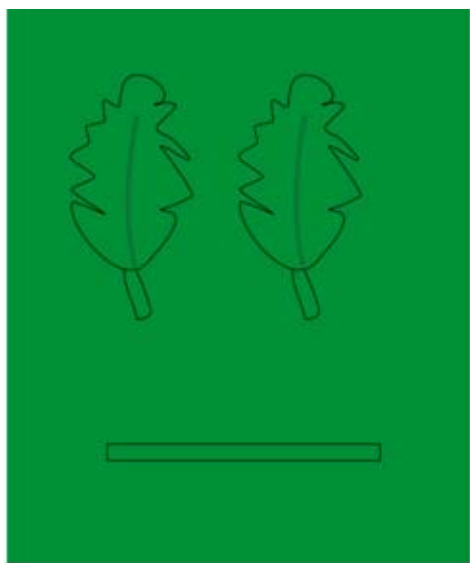

10



11



12



13



Гүлді өсіруші кәсіп иелері туралы мәлімет жина және сыныптастарыңмен талдау жаса.



Өзіндік жұмыс үлгілері.

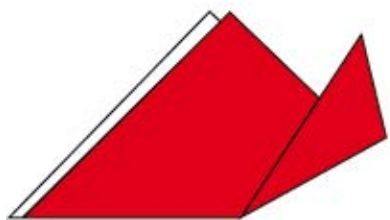

1



2

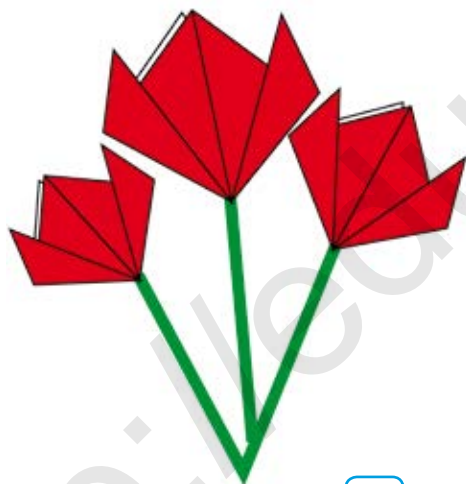

3

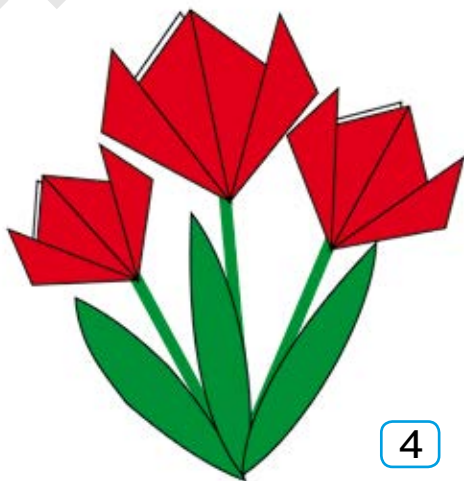

4



Қызғалдақты түрлі материалдардан өздігіңнен жасап көр.



## 4-бақылау жұмысы

Түрлі қағаздардан композиция жасау



## ЖАЗДЫҢ АППЛИКАЦИЯСЫН ЖАСАУ



Қағаздан «Жаз» тақырыбын аппликация әдісінде даярла.

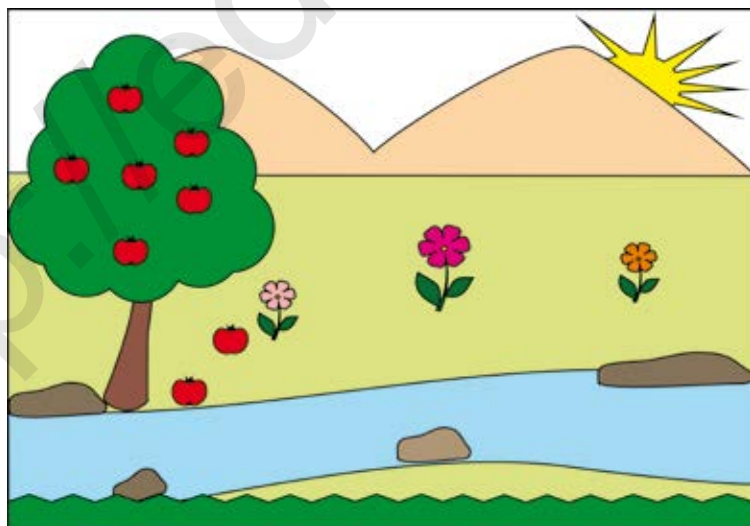
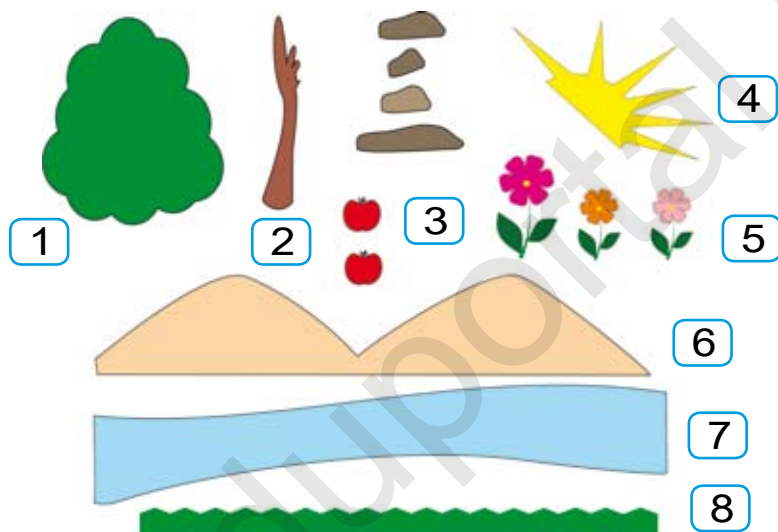



Өзіндік жұмыс үлгілері.





Өзіндік жұмыс үлгілері.

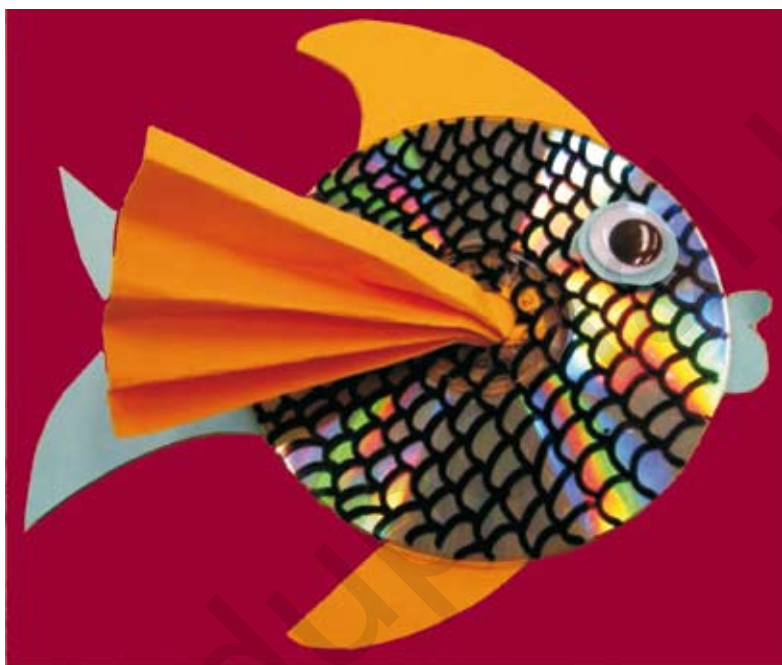

## МАЗМҰНЫ

|   |    |
|---|----|
| <b>Кіріспе</b> .....  | 3  |
| Технология сабағында орындалатын жұмыс үлгілері ...                                 | 4  |
| «Күздің» көрінісін аппликация әдісінде жасау .....                                  | 5  |
| Көбелектің пішінін құрастыру, жасау .....   | 7  |
| Қозғалатын ойыншықтар жасау .....   | 10 |
| Сабаннан аппликация әдісінде хайуандар,<br>гүлдер, жануарлардың пішінін жасау ..... | 14 |
| «Ертегі қаһармандарын» аппликация әдісінде жасау ..                                 | 17 |
| Папье-маше әдісінде пияла жасау және безендіру .....                                | 21 |
| Сыйлық үшін сувенир жасау .....   | 24 |
| Түрлі қағаздардан гүлтізбектері мен қардың жұлымын<br>жасау .....                   | 27 |
| Түсті қағаздан шырша жасау .....  | 30 |
| Қыстың көрінісін аппликация әдісінде жасау .....                                    | 34 |
| Кестені дұрыс тігу .....  | 36 |
| Ине үшін жастық тігу .....  | 42 |
| Әр түрлі геометриялық пішіндерден қозғалатын<br>модельдерді құрастыру, жасау .....  | 44 |
| Көктемгі гүлдердің композициясын даярлау .....                                      | 47 |
| Қағазды бүктеу және қырку әдісінде гүлдердің<br>пішінін жасау .....                 | 48 |
| Мерекеге құттықтау қағазын жасау .....  | 50 |
| Наурыз мерекесі үшін әшекейлер даярлау .....  | 56 |
| «Вазада гүлдер» композициясын жасау .....   | 58 |
| Жүзетін модельдердің макетін құрастыру, жасау .....                                 | 63 |

|   |    |
|---|----|
| Поролон және жіптен жұмсақ ойыншықтар даярлау ...                   | 65 |
| Жіптен ойыншықтар жасау .....                                       | 68 |
| Қағазды қырку және бүктеу әдісінде гүлдердің<br>пішінін жасау ..... | 69 |
| Жаздың аппликациясын жасау .....                                    | 74 |

*O'quv nashri*

Xamrakul SANAKULOV,  
Dilrabo XODIYEVA, Aziza SANAKULOVA

## **TEXNOLOGIYA**

**Umumiy o'rta ta'lim maktablarining  
3-sinfi uchun darslik**

*(Qozoq tilida)*

«Sharq» nashriyot-matbaa  
aksiyadorlik kompaniyasi  
Bosh tahririyati  
Toshkent – 2019

Аударған Д. Бектаева  
Редактор Ф. Есиркепова  
Керкемдеуші Т. Қаноатов  
Техникалық редактор Р. Нафасов  
Корректор Ш. Бектаев  
Беттеген М. Атхамова

**Баспа лицензиясы AI № 201, 28.08.2011-ж.**

Басуға рұқсат етілді 07.06.2019. Пішімі 70x90  $\frac{1}{16}$ .  
«Arial» гарнитурасы. Кеглі 14. Офсеттік әдіспен басылды.  
Шартты баспа табақ 5,85. Баспа есеп табағы 2,61.  
Таралымы 5532 нұсқа. Тапсырыс № 447.

**«Шарқ» баспа-полиграфиялық акционерлік компаниясының  
баспаханасы, 100000, Ташкент қаласы,  
«Buyuk Turon» көшесі, 41.**

Жалға берілген оқулықтың жағдайын көрсететін кесте

| № | Оқушының атыжөні | Оқу жылы | Оқулықтың алғандағы күйі | Сынып жетекшісінің қолы | Оқулықтың тапсырылғандағы күйі | Сынып жетекшісінің қолы |
|---|------------------|----------|--------------------------|-------------------------|--------------------------------|-------------------------|
| 1 |                  |          |                          |                         |                                |                         |
| 2 |                  |          |                          |                         |                                |                         |
| 3 |                  |          |                          |                         |                                |                         |
| 4 |                  |          |                          |                         |                                |                         |
| 5 |                  |          |                          |                         |                                |                         |

Оқулық жалға берілгенде және оқу жылының соңында қайтарып алынғанда жоғарыдағы кестені сынып жетекшісі төмендегі бағалау өлшемі негізінде толтырады.

|        |   |
|--------|---|
| Жана   | Оқулықтың бірінші рет пайдалануға берілгендегі күйі.  |
| Жақсы  | Мұқабасы бүтін, оқулықтың негізгі бөлігінен ажыралмаған. Барлық парақтары бар, жыртылмаған, көшпеген, беттерінде жазулар мен сызықтар жоқ.  |
| Орташа | Мұқабасы мыжылған, едәуір сызылып, шеттері жейілген, оқулықтың негізгі бөлігінен ажыралуы мүмкін, пайдаланушы тарапынан қанағаттанарлы қапталған, түсіп қалған беттері қайта тігілмеген, кейбір беттеріне сызылған. |
| Нашар  | Мұқабасына сызылған, жыртылған, негізгі бөлігінен ажыралған яки түгелдей жоқ, қанағаттанарсыз қапталған. Беттері жыртылған, парақтарын, оқулықты тіктеп болмайды.   |



*O'quv nashri*

Xamrakul SANAKULOV,  
Dilrabo XODIYEVA, Aziza SANAKULOVA

## **TEKNOLOGIYA**

**Umumiy o'rta ta'lim maktablarining  
3-sinfi uchun darslik**

*(Qozoq tilida)*

«Sharq» nashriyot-matbaa  
aksiyadorlik kompaniyasi  
Bosh tahririyati  
Toshkent – 2019

Аударған Д. Бектаева  
Редактор Ф. Есиркепова  
Көркемдеуші Т. Қаноатов  
Техникалық редактор Р. Нафасов  
Корректор Ш.Бектаев  
Беттеген М. Атхамова

**Баспа лицензиясы AI № 201, 28.08.2011-ж.**

Басуға рұқсат етілді 07.06.2019. Пішімі 70x90  $\frac{1}{16}$ .  
«Arial» гарнитурасы. Кеглі 14. Офсеттік әдіспен басылды.  
Шартты баспа табақ 5,85. Баспа есеп табағы 2,61.  
Таралымы 608 нұсқа. Тапсырыс № 447-А.

**«Шарқ» баспа-полиграфиялық акционерлік компаниясының  
баспаханасы, 100000, Ташкент қаласы,  
«Buyuk Turon» көшесі, 41.**